

# **Perspectives and Challenges of EU Electricity Enlargement - Benchmarking the Reforms of the Electricity Sector in the New Member States**

**Christian von Hirschhausen and Georg Zachmann**

## **WP 5 Report of the SESSA Project<sup>1</sup>**

**revised, May 2005**

### **Abstract**

- 1. Introduction**
- 2. Survey of the Region**
  - 2.1 Overview
  - 2.2 Central European Countries (CECs)
  - 2.3 South East Europe (SEE)
  - 2.4 Baltic Countries
- 3. Benchmarking the Reform Process in the New East European EU Member Countries**
  - 3.1 The EU Annual Benchmarking Exercise
  - 3.2 The EBRD Infrastructure Reform Indicators
  - 3.3 OXERA-DIW/EE<sup>2</sup> Benchmarking Indicators
  - 3.4 Remaining Obstacles to Competitive Markets
- 4. Generation Adequacy, Fuel Mix, and Sustainability**
  - 4.1 Generation Adequacy
  - 4.2 A “Politically Incorrect” Fuel Mix: Coal and Nuclear
  - 4.3 Insufficient Incentives for the Promotion of Renewable Energy
- 5. Network Interconnection and Regional Markets**
  - 5.1 Three Regional Markets
  - 5.2 Congested Transmission Lines
  - 5.3 More Efficient Allocation Mechanisms Required
- 6. Conclusions**
- 7. References**

### **Abstract**

This paper summarizes the main findings of Work Package 5 of the SESSA project on “Ensuring Sustainable Electricity Enlargement”. It provides a survey survey of the main structures of the electricity sector in the East European new EU-member countries (Poland, Czech Republic, Slovakia, Hungary, Lithuania, Latvia, Estonia, Slovenia) and candidate countries (Romania, Bulgaria, Croatia). The paper’s focus is on benchmarking the reform process in the region, using qualitative and quantitative ranking methods. It also discusses open policy issues regarding investment adequacy, fuel mix, and interregional electricity trading. We find that while all countries have implemented some reforms, most of the objectives stated in the Acceleration Directive 2003/55/EU are yet to be achieved. EU-electricity enlargement, and the creation of a truly internal market, are far from being achieved.

---

<sup>1</sup> The report summarizes the background research of Work Package 5 (“Ensuring Sustainable Electricity Enlargement”) of the SESSA-Project (European Forum on Electricity Regulation), as well as the findings of the Berlin SESSA-WP5 Conference (December 2004). We thank Jürgen Apfelbeck, Astrid Cullmann, and Sophia Ruster and for research assistance. The usual disclaimer applies.

## **1. Introduction**

In May 2004 the EU integrated eight countries from Central and Eastern Europe, as well as Malta and Cyprus, into what is about to become a truly pan-European Union. But whereas the political EU-enlargement is proceeding smoothly, electricity enlargement turns out to be a more complex undertaking, which is far from being achieved at present. Since the mid-1990's, the accession countries had worked hard to bring their energy sectors in conformity with the EU *acquis communautaire*. The objective of this paper is to provide a balanced assessment of this process until today, to identify successes and challenges lying ahead, and to derive policy recommendations how to foster the reform process in the region.

The objective of EU electricity enlargement is to move towards a *single, sustainable* European electricity market. A *single* market refers to the expectation of a competitive market and the efficient allocation of generation and transmission resources, at least at a regional level, if not at the level of the new EU 25 at large. *Sustainable* refers to the ability of the electricity system to meet the environmental objectives of the EU, in particular with regard to the share of renewables in electricity production and the greenhouse gas targets, while assuring reliable electricity supply at reasonable costs. Establishing open, competitive markets while at the same time pursuing environmental objectives is not necessarily a contradiction. A benchmarking approach of comparing different reform objectives can make cross-country comparisons possible. In this paper, we discuss various such benchmarking methodologies and the results they yield for Eastern Europe.

This paper summarizes the main findings of Work Package 5 of the SESSA project on "Ensuring Sustainable Electricity Enlargement". We report on our own research findings, the outcomes of the international SESSA conference in Berlin, December 2004 (see Hirschhausen and Zachmann, 2004), and we also refer to the companion papers by Haas, et al. (2005), Kaderjak (2005), and Zachmann (2005). The paper is structured in the following way: Section 2 introduces the region and provides a survey of the main structures of the electricity sector in each country. Section 3 then provides a benchmarking exercise of the reform process in the region, with a focus on the setting up of competitive market structures. Benchmarking and the identification of good practice being the main objectives of the SESSA-project, we assemble all available information from different international organizations (EU, EBRD); in addition, we present our own in-depth research and data collection on the regulatory regimes prevailing in these countries. Section 4 then deals with the current and future fuel mix, investment, and sustainability issues related thereto. Then we turn to issues of electricity trade and interconnection (Section 5). In particular, we analyze how far the East European countries are on their way to regionally integrated markets. Section 6 concludes.

## **2. Survey of the Region**

### **2.1 Overview**

The new East European EU member countries (Poland, Czech Republic, Slovakia, Hungary, Lithuania, Latvia, Estonia, Slovenia) and candidate countries (Romania, Bulgaria, Croatia) share a common point of inception: until the late 1980s they were part of the socialist block, in political and economic, but also in technical terms. Except Croatia and Slovenia (as part of former Yugoslavia), the East European countries were part of the COMECON (Council for Mutual Economic Assistance)

which organized the socialist division of labor, leading to highly concentrated, ineffective electricity industries. Thus, in the early 1990s, these countries were faced with outdated and polluting power plants, one-sided network integration towards the East, a distorted price structure, and inefficient management structures.

Subsequently, the last 15 years were characterized by a very tough transformation process from socialist structures towards market economies. The price system had to be changed from “social tariffs” to cost-covering, and yet efficient prices. The vertically integrated monopolies had to be unbundled. Even regional units had to be disintegrated due to new political borders (Czechoslovakia, Yugoslavia, Soviet Union). Parts of the unbundled monopolists were privatized. Regulation authorities were established and environmental standards as well as renewable-promotion schemes were implemented. In brief, the CEECs experienced 50 years of gradual reforms of the West European power sector in only 15 years.<sup>2</sup>

In economic terms, the region features the lowest per capita incomes in the entire European Union (between 1500 € per capita in Romania and 10,700 € per capita in Slovenia). The total GDP of the new East European EU member countries plus Bulgaria and Romania is at 360 Bill. € (in prices of 1995); thus, it is lower than the GDP of the Netherlands (390 Bill. €). In terms of electricity generation capacity and production, too, the new member countries are small or very small: only Poland (31 GW installed capacity, 133 TWh generated in 2002) is comparable in size with the larger EU-15 countries, followed by the Czech Republic (15 GW, 70 TWh) and Romania (17 GW installed, 50 TWh generated). On the other hand, countries like Latvia (2.2 GW, 3.7 TWh), or Estonia (2.4 GW, 12.5 TWh) are almost negligible at the European level. The capacity of the entire region (89 GW, 401 TWh) corresponds to not more than the size of the French or the German electricity sector alone.

With accession to the European Union, the new member states have committed to certain policies with regard to their electricity sector. The most important one is the electricity directive 2003/54/EC<sup>3</sup> (“Acceleration Directive“) as the key European legislation establishing the internal market of electricity. It requires unbundling of transmission and distribution, non-discriminatory access to the transmission and the distribution networks, and a low market concentration. The regulation 1228/2003/EEC<sup>4</sup> on cross-border trade in electricity sets rules for transmission of electricity between Member States. This regulation that lays down basic principles of tariffication and capacity allocation entered into force 1 July 2004; it is directly applicable Community law. In addition, decision 1229/2003/EC<sup>5</sup> establishes a set of guidelines relating to trans-European energy sector networks. The directive 2001/77/EC<sup>6</sup> stipulates that electricity generated from renewable sources shall amount to 22% of total electricity production. However the targets for the new member states are in general significantly lower. The reduction of greenhouse gases via an emission allowance trading scheme is

---

<sup>2</sup> See Newbery (1994), Stern (1998) and Hirschhausen (2002, Chapter 9) for a general presentation of the transition process in the electricity sector.

<sup>3</sup> Directive 2003/54/EC of the European Parliament and of the Council of 26 June 2003 concerning common rules for the internal market in electricity and repealing directive 96/92/EC, OJ L 176/37 15.07.2003.

<sup>4</sup> Regulation No 1228/2003/EC of the European Parliament and of the Council of 26 June 2003 on conditions for access to the network for cross – border exchanges in electricity OJ L 176/1 15.07.2003.

<sup>5</sup> Decision No 1229/2003/EC of the European Parliament and of the Council laying down a series of guidelines on trans-European energy networks and repealing Decision No 1254/96/EC: OJ L 176 15.7.2003.

<sup>6</sup> Directive 2001/77/EC of the European Parliament and of the Council of 27 September 2001 on the promotion of electricity produced from renewable energy sources in the internal electricity market OJ L 283/33 27.10.2001.

implemented in directive 2003/87/EC<sup>7</sup>. Finally, directive 2001/80/EC<sup>8</sup> limits the emissions of certain pollutants into the air.

When considering the electricity map of the region, one clearly distinguishes three sub-regions:

- The Central European Countries (CEC) are the former CENTREL-countries (Poland, Czech and Slovak Republics, Hungary) which are emerging as the core-zone in Eastern Europe; we consider Slovenia and Croatia also as being part of this region. These countries present by far the biggest market and assemble the strongest players of the region;
- South Eastern Europe (SEE) consists of the EU candidates Romania and Bulgaria as well as the other Balkan states (except Albania);<sup>9</sup>
- The Baltic countries (Lithuania, Latvia, Estonia) are still part of the North-West Russian electricity system. The electricity sector in the Baltic countries is infinitesimally small, but it is politically highly sensitive (nuclear power in Ignalina/Lithuania, geopolitical issues with Russia, Kaliningrad, etc.).

In the following, we will briefly outline the main tendencies in the countries of each of the regions (for more technical details see EBRD (2004), Haas, et al. (2005), Kaderjak (2005), Kennedy (2003)). We focus on regulatory issues, but we also comment on market structure and fuel mix.

	<b>Population 2002 in Mill.</b>	<b>GDP 2004 in Bill. € (in prices of 1995)</b>	<b>GDP 2004 per Capita in €</b>	<b>Net-max capacity 2002 GW</b>	<b>Electricity Production 2002 in TWh</b>	<b>Peak Load 2002 in GW</b>
<b>Czech Republic</b>	10,2	51	5000	15,1	70,4	10,3
<b>Estonia</b>	1,4	5	3500	2,4	12,5	1,3
<b>Hungary</b>	10,2	48	4700	7,7	33,7	6,0
<b>Latvia</b>	2,3	6	2800	2,2	3,7	1,2
<b>Lithuania</b>	3,5	8	2300	5,8	16,1	1,7
<b>Poland</b>	38,2	150	3900	31,3	132,6	21,3
<b>Slovakia</b>	5,4	21	3900	7,8	30,6	4,1
<b>Slovenia</b>	2,0	21	10700	2,9	13,0	1,9
<b>Bulgaria</b>	8,0	12	1500	6,8	38,6	6,8
<b>Romania</b>	22,3	32	1500	17,3	50,4	7,6
<b>Sum CEECs</b>	103,5	354	3400	99,3	401,6	62,2
<b>Germany</b>	82,5	2107	25500	124,4	544,6	79,7

Source: Eurelectric (2004), Eurostat

**Table 1: Overview of the East European economies and electricity sectors in 2002**

<sup>7</sup> Directive 2003/87/EC of the European Parliament and of the Council of 13 October 2003 establishing a scheme for greenhouse gas emission allowance trading within the Community and amending Council Directive 96/61/EC

OJ L 275 25.10.2003.

<sup>8</sup> Directive 2001/80/EC of the European Parliament and of the Council on the limitation of emissions of certain pollutants into the air from large combustion plants OJ L 309, 27.11.2001.

<sup>9</sup> These countries are peripheral to the new EU-27, but have a very important role to play for stabilization and growth in the Balkan region.

## 2.2 Central European Countries (CECs)

The Central European Countries (Poland, Czech Republic, Slovakia, Hungary, Slovenia, Croatia) dominate the electricity enlargement process. They have been central in recent UCTE-extensions, and also attract most foreign direct investment. Most of the CECs are characterized by a partially privatized generation sector, partly privatized distribution utilities, and state owned transmission companies.

In *Poland* the generation sector is divided in three major groups: Południowy Koncern Energetyczny (PKE), which is partially privatized and has a market share of around 20%, Bełchatów Opole Turów Group (BOT), which is in state ownership and also has 20% market share, and Polskie Sieci Elektroenergetyczne SA (PSE), the state owned transmission system operator, which also owns some generation capacities.<sup>10</sup> The majority (70%) of electricity distribution is still state owned.<sup>11</sup> With the amendment to the Energy Law Act in July 2002, the Polish law was harmonized with the European regulations. Since January 2004 Polish customers consuming more than 1 GWh per year (53% of the market) have been eligible; as from January 2006 all consumers are eligible. Apart of final unbundling of the activities of PSE (TSO, generation and electricity trade) generation, transmission and distribution activities are carried out by different companies. Though Poland has the largest power exchange in the CECs, liquidity is still insufficient (1.9 TWh traded in the spot market of the PolPX in 2004, representing 1.5% of total Polish electricity consumption) to generate competitive wholesale prices.

Generation in the *Czech Republic* is dominated by CEZ (60 % market share), a joint stock company of which 68% is state-owned. The transmission system operator CEPS was recently unbundled from CEZ and is now in separate state ownership. The ownership structure of the 8 distribution utilities was recently restructured. CEZ controls 5 regional distribution companies, the other 3 utilities are majority owned by E.on (2) and RWE/EnBW (1). The state owned market operator OTE organizes a day-ahead and a balancing market. Regulated third party access to the transmission grid should be assured by the Energy Regulation Office (ERU), which is financed from the state budget. ERU is also responsible for granting licenses, regulating prices for non-eligible customers and charges for network and ancillary services. An amendment of the Energy Act adopted in 2003 accelerated electricity market opening: from 2005 all final customers excluding households are eligible, and from 2006 the electricity market will be fully open.

*Hungary*, sometimes considered to be the most reform-oriented Central-East-European-country, is characterized by mainly privatized generation utilities, a virtually fully privatized distribution sector, and an independent system operator. However some features of the market structure are still hindering efficient competition: the generation market share of 40% underestimates the central position of Magyar Villamos Művek Rt. (MVM), the state owned conglomerate. MVM still dominates the Hungarian market, mainly through its monopoly for sales to captive consumers, its vertical integration

---

<sup>10</sup> In addition to these three major producers, foreign investors such as EdF, Electrabel, Vattenfall have assets in some IPPs.

<sup>11</sup> Only the two smallest of the seven distribution companies (these were grouped together from former 29 companies) were sold to Vattenfall and RWE.

with the transmission grid owner OVIT, its portfolio of long term contracts and its possession of the cheapest generation capacity (Paks nuclear power plant). The Hungarian Energy Office (HEO) is responsible for the regulation of electricity, gas and district heating markets. With its income from a tax on the previous years net earnings of all licensed energy utilities (0.05%) the office is independent from the state. Since July 2004 all non-household consumers are free to choose their supplier. This high degree of market opening however does not translate into a competitive market because most of the power producers are fixed to MVM through long term power purchase agreements. Import capacities are insufficient to generate competition from outside.

In *Slovakia* the generation sector is dominated by Slovenské Elektrárne, a.s. (SE, about 85 % of total generation). ENEL recently bought a 66% share of the former state owned monopolist for 840 mn. €. Distribution, transmission and generation are fully unbundled. The Slovak transmission system operator SEPS is still in 100% state ownership and has to provide regulated third party access There are 3 regional distribution companies, which are partly owned by EdF, Eon and RWE, while the majority of stakes (51% each) are state owned. RONI (Regulatory Office for Network Industries) is responsible for regulating prices, tariffs and tariff conditions of energy supply.

*Slovenia* is characterized by an unbundled but completely state controlled electricity sector. Generation is dominated by Holding Slovenske Elektrarne (HSE) and Nuklearna Elektrarna Krsko (NEK) which controls the Krsko nuclear power plant (its output is shared equally between Croatia and Slovenia). Together these two state owned utilities have a market share of more than 80%. The transmission system operator ELES is also in 100% state ownership. The distribution sector is organized in five regional monopolies where the state holds majority assets of 79.5% in each. The changes of the Electricity Act, following Directive 2003/54/EC, were adopted in Parliament in May 2004. The market will be opened to households in July 2007. The Agency for Energy issues licenses, regulates network prices, resolves disputes on TPA and ensures transparent and non-discriminatory operations of the market. However the decision on prices for non-eligible consumers still lies within the government. A day-ahead market for standardized products is organized by the market operator "BORZEN".

*Croatia* is still dominated by a vertically integrated, state-owned monopoly (HEP). In July 2002, formal unbundling took place, but all entities (generation, transmission, distribution) still belong 100% to the Republic of Croatia. According to the HEP Privatization Act, at least 51 % of HEP shares will remain state-owned until Croatia's accession to the European Union. In July 2001 the Energy Law was adopted along with the Law on the Regulation of Energy Activities and a number of specific laws governing individual energy activities. The prices of electricity for tariff customers are set by the Government and the Energy Regulatory Council. The Electricity Market Law regulates that all electricity customers with an annual electricity consumption exceeding 40 GWh can become eligible customers.<sup>12</sup> Prices in Croatia are still below costs.

---

<sup>12</sup> The main tasks of the regulator in the field of electricity include: issuing licenses to energy undertakings, ensuring proper functioning of the electricity market, controlling free access to the network, approving construction plans and regulating electricity prices for tariff customers and prices of individual system infrastructure services.

### **2.3 South East Europe (SEE)**

South East Europe (SEE) consists of a small, yet balkanized electricity sector, which is only gradually recovering from the devastating effects of transition and civil war in the former Yugoslavia. A symbolic success was the synchronization of the region with the 1<sup>st</sup> tier UCTE-grid, in December 2004. However, big efforts will be required to achieve a workable regional market. The two EU candidate countries that we focus on in this paper, Romania and Bulgaria, are the heavy weights in the region, whereas the republics of former Yugoslavia (Serbia, Bosnia-Herzegovina, Macedonia) are peripheral to the future EU electricity market. Romania and Bulgaria are characterized by an almost completely state owned generation sector, only a small share of privatized distribution companies, and a state owned TSO. Although all stages of the value chain are mainly in state ownership, the countries unbundled them vertically and horizontally, often with the aim of future privatization.

The *Romanian* state owns one nuclear, one hydro and seven thermal power generation companies which are producing 85% of the domestic output. The remaining 15% are generated by independent power producers. 25 to 40% of the thermal power plants are to be privatized. The TSO Transelectrica is in full state ownership. The power market is managed by OPCOM - the Power Market Operator, a wholly owned subsidiary of Transelectrica. Among the 8 regional distribution companies four are state owned, two are in the process of privatization (RWE, CEZ) and two have already been privatized (ENEL). The Romanian Energy Law nr. 318 from 2003 is in force since August 2003. Since January 2004 legal market opening is established at 40 %. The Romanian Electricity and Heat Regulatory Authority (ANRE) is financially independent from the state budget and derives its funds mainly from contributions of regulated entities and licensing activities. Its main responsibilities are issuing licenses, setting prices and tariffs for the captive consumers, and approving secondary legislation.

*Bulgaria* has six state owned and some private generation companies. Natsionalna Elektricheska Kompania EAD (NEK), the former vertically integrated monopolist, has now unbundled its distribution and generation activities (apart of some hydro power plants) and concentrated on its role as TSO. The Bulgarian distribution sector consists of one private and 7 state owned regional distribution companies. At present. Bulgaria performs significant privatization efforts in the distribution and generation sector. The new Energy Law which is in force since December 2003, introduces a new power market design, replacing the “single buyer” model by a model of “bilateral contracts and a balancing market” based on the principles of regulated Third Party Access. Market opening for all non-household customers will be 100% by January 2007, and all customers (including households) will be eligible by July 2007. The fulfillment of the European unbundling requirements is scheduled for December 2005 (transmission and wholesale) and December 2006 (distribution and supply). The Bulgarian regulatory authority is the State Energy Regulatory Commission (SERC).

### **2.4 Baltic Countries**

The three Baltic countries (Lithuania, Latvia, Estonia) have joined the EU politically; yet electricity-wise they are still part of the North-West Russian electricity system. The *Lithuanian* generation sector is dominated by the state owned Lietuvos Elektrine which operates the Ignalina nuclear power station (share of 77% of domestic generation). Although it has to be decommissioned by 2009 entirely according to commitments to the EU (the 1st block was shut down in 2004), it is unclear if this will materialize. Lietuvos Energija, the Lithuanian TSO is 96% state owned. Apart from the grid it also owns two hydro plants and is active as market operator. Distribution is provided by two partly

privatized regional distribution companies. Thus, unbundling is achieved, albeit by state-owned companies. Prices for non-eligible consumers as well as tariffs for natural monopolists services are regulated by the National Control Commission for Prices and Energy. For transmission and distribution services TPA is applied.

In *Latvia* the energy sector remains dominated by the vertically integrated, 100% state owned Latvenergo, which still controls generation, transmission (HVEN), most of distribution, district heating and sales. The unbundling of accounting within Latvenergo has been achieved in 1998. From June 2004, the market has been opened for all non-household customers. Regulated Third Party Access (rTPA) is applied. The Public Utilities Commission is responsible for the electricity sector and it sets tariffs for all parts of Latvenergo.

Generation, transmission, distribution and sale of electricity in *Estonia* are dominated by Eesti Energia AS the vertically integrated infrastructure company. Estonia remains the largest producer of oil-shale in the world even today (70% of world market share). Its two oil-shelf fired Narva Power Plants account for more than 90% of Estonia's installed capacities. There are only two foreign-owned distribution companies. Since April 1999, Eesti Energia has started to unbundle accounts and management of different business units. The basis for regulation of the electricity sector in Estonia is the Electricity Market Act which came into force in July 2003. The law grants a market share of 90% to Eesti Energia. According to the Accession Treaty with the European Union, Estonia will open 35 % of its electricity market until end of 2008. Thereafter, the market will be gradually opened for all customers by the end 2012. These measures were taken to protect the local oil shale industry (mining, power plants) from outside competition for a transition period. The Energy Market Inspectorate (EMI) is responsible for issuing market licenses for import, export, and sales of electricity. It also approves electricity prices of different participants in the market.

### **3. Benchmarking the Reform Process in the New East European EU Member Countries**

The former section indicates that although some progress has been achieved, in commercial and regulatory terms the adaptation process leaves many reform steps to be desired. Most new member countries have only achieved "semi-commercialization" (Stern, 2004). Price adaptation towards full cost-recovery and an adequate relation between industry and household prices has not been achieved in many countries yet. Effective regulation is lacking in several countries where regulators have only a limited degree of independence and capacity. This hampers the emergence of a stable energy policy environment. Privatization of generation and distribution companies, pushed strongly in the early reform phase, has decelerated recently. Customer switching is gaining importance for industrial customers in some countries, but domestic retail competition, an objective of the EU Directive, is still underdeveloped (and generally not even allowed).

The question whether the glass is "half-empty" or "half-full" is open to debate. This section should clarify some issues by providing a comparative quantitative analysis of the reform process in the East European countries. In particular, we compare different benchmarking approaches that have been developed to quantify the reform efforts in the region, and we make them comparable between the different countries. We also provide our own assessment of reform efforts in the new EU member countries.

### **3.1 *The EU Annual Benchmarking Exercise***

Since the 2002 Barcelona Summit, the European Commission established annual reports on the implementation of the gas and electricity internal market. The fourth Benchmarking Report (European Commission, 2005) is the first that provides a full assessment of the new member states. The main issues discussed in the report are unbundling and regulation, market structure and the degree of vertical integration, and price formation, including the role of long-term power purchase agreements (PPA).

Table 2 summarizes the findings of the Benchmarking Report. Overall, the new member states receive a rather critical assessment: most new member states range in the lower half of the EU-countries. Unfavourable assessments are given for the unbundling of distribution system operators, consumer switching, market concentration (for some of the countries), the insufficient role of wholesale markets, the little progress in creating balancing markets, and the persistence of non-market based long-term power purchase agreements (PPA). Almost all new member states are classified as having major obstacles to competition. Concretely, the lack of a diversified market structure is seen as a main obstacle to competition in Latvia, Slovenia, the Czech Republic, the Slovak Republic, and Lithuania. Regulated end-user prices and/or the continued use of non-market based long-term power purchase agreements are rated negatively in Estonia, Poland and Hungary. (European Commission, 2005, 5). The Benchmarking Report also criticizes the lack of integration of many East European countries with the rest of the European energy market.

	<b>Declared market opening (%)</b>	<b>Unbundling: transmission system operator /owner</b>	<b>Unbundling: distribution system operator</b>
<b>Czech Rep.</b>	47	Legal	Accounts
<b>Estonia</b>	10	Legal	Legal
<b>Hungary</b>	67	Legal	Accounts
<b>Latvia</b>	76	Accounts	Accounts
<b>Lithuania</b>	n.c.	Legal	Legal
<b>Poland</b>	52	Legal	Accounts
<b>Slovakia</b>	66	Legal	Management
<b>Slovenia</b>	75	Legal	Accounts
<b>Romania</b>	33	Legal	Management
<b>Bulgaria</b>	22	Accounts	Accounts

Source: EU (2005)

	<b>Biggest generators' share of capacity (%)</b>	<b>Biggest 3 generators' share of capacity (%)</b>	<b>Companies with at least 5% share of installed capacity</b>	<b>Import capacity (as % of installed capacity)</b>
<b>Czech Rep.</b>	65	75	1	23%
<b>Estonia</b>	90	100	2	66%
<b>Hungary</b>	30	65	6	38%
<b>Latvia</b>	95	100	1	100%
<b>Lithuania</b>	50	80	3	50%
<b>Poland</b>	15	35	8	10%
<b>Slovakia</b>	75	85	1	37%
<b>Slovenia</b>	70	95	3	68%
<b>Romania</b>	n.k.	n.k.	7	16%
<b>Bulgaria</b>	n.k.	n.k.	7	20%

Source: EU (2005)

**Table 2: Summary of the 4th EU benchmarking report (2005) on electricity sector reform in the new member countries**

<b>Balancing regime favorable\ prices in line with norm</b>	DK, FI, SE, UK, NO, IE, ES,
<b>Some favorable elements</b>	AT, FR, IT, NL, PT, <b>LT, LV, CZ, SK, HU, SI</b>
<b>Out of line with norm or unclear</b>	DE, BE, GR, <b>EE, PL</b>

Source: European Commission (2005); new member countries in bold

**Table 3: Summary of balancing regimes in the EU (defined in the 4th EU benchmarking report)**

### **3.2 The EBRD Infrastructure Reform Indicators**

A second benchmarking exercise is carried out by the European Bank for Reconstruction and Development (EBRD). EBRD follows the reform process in the region by establishing “infrastructure reform indicators”, published in the annual EBRD Transition Reports (various issues). The evaluation is based on three criteria:

- *tariff reform*, that is the introduction of cost-covering and allocative efficient price structures;
- *commercialization*, that is the transformation of corporate governance structures, the introduction of hard budget constraints and, possibly, privatization; and

- *regulatory and institutional reform*, that is the instauration of independent regulatory agencies with appropriate checks and balances, the definition of the formal institutional framework and the like.

The scale of the reform indicators ranges from 1 (no market economy-oriented reforms at all) to 4.3 (full implementation of the sectoral regulation of Western European style market economies). For the electricity sector, EBRD orients its rating assessment at the stylized vision of a competitive unbundled and fully commercialized industry.<sup>13</sup>

Figure 1 provides the electricity reform indicators by EBRD for the East European countries since 1998. The data shows a large variety of situations: A few new member states have reached a level comparable to the “normal” standards required from EU member countries; among them are Hungary and the Slovak Republic. Some countries show a dynamic development from rather modest levels in the mid-1990’s towards a normalization today (e.g. Bulgaria, Czech Republic). However, in some other countries the reform process seems to have stalled, or is progressing only slowly; this is the case for Estonia and Poland, for example.

---

<sup>13</sup> More precisely, EBRD defines the following characteristics for the scores (EBRD, 2004):

Score 1- The power sector operates as a government department. There is political interference in running the industry, with few commercial freedoms or pressures. Average prices are below costs, with eternal and implicit subsidy and cross-subsidy. Very little institutional reform has been achieved. There is a monolithic structure with no separation of different parts of the business;

Score 3 - A law has been passed providing for full-scale restructuring of the industry, including vertical unbundling through account separation and setting-up of a regulatory. Some tariff reform and improvements in revenue collection have been achieved, and there is some private sector involvement;

Score 4.3 – Business has been separated vertically into generation, transmission, and distribution. An independent regulatory has been set up, with full power to set cost-reflective effective targets. There is large-scale private sector involvement. Institutional development has taken place, including arrangements for network access and full competition in generation.

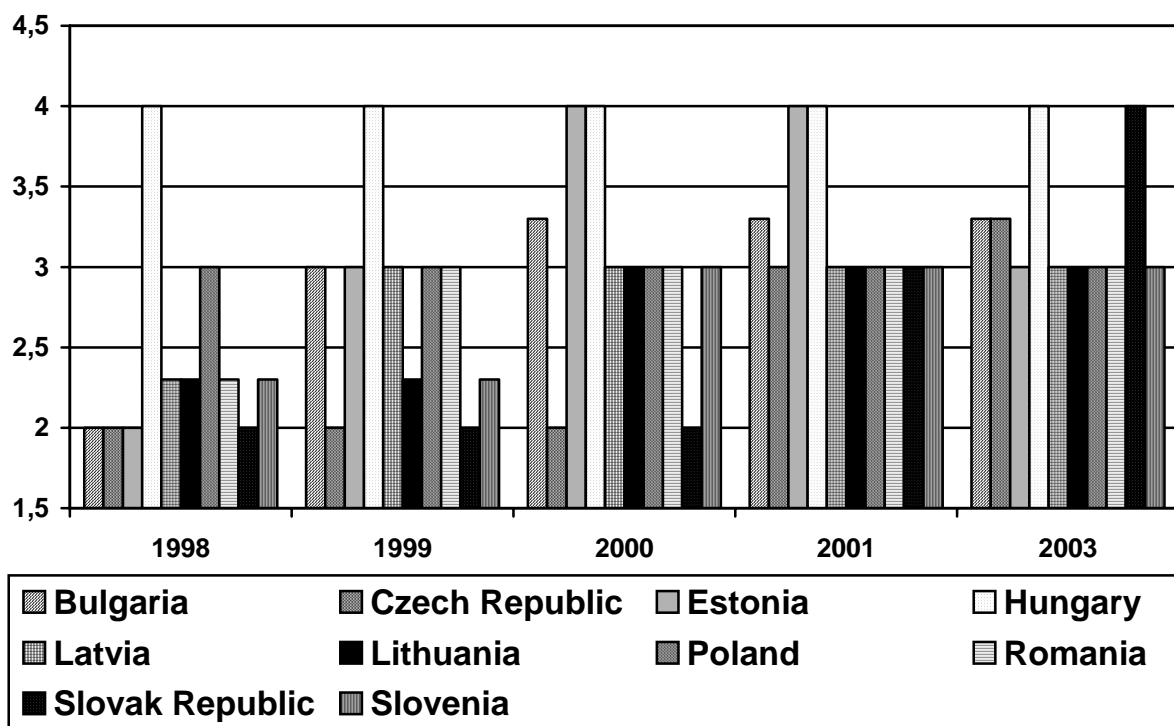

Source: EBRD (2004)

Figure 1: EBRD electricity sector reform indicators for Eastern Europe (1998-2003)

### 3.3 OXERA-DIW/EE<sup>2</sup> Benchmarking Indicators and Comparison

An even more detailed benchmarking indicator has been assembled in the framework of the SESSA-project by DIW Berlin and the Chair of Energy Economics (EE<sup>2</sup>) at Dresden University of Technology (see Apfelbeck and Pessier, 2005). It is based on the methodology proposed by OXERA in its study on benchmarking EU electricity reforms (OXERA, 2003). The objective is to develop a methodology for quantifying the competitiveness of energy markets. The indicator takes into account the state of competitiveness at each stage of the supply chain (upstream, wholesale markets, network and retail), referring to economic theory and analysis of current practices by regulatory and competition authorities. Sub-scores (each one ranging from 0 to 10) are then aggregated to derive an overall electricity market competitiveness score (see Figure 2).

Figure 3 reports the competitiveness scores for East European countries calculated by Apfelbeck and Pessier (2005, 61 sq). There is more diversity in the scores than in the EBRD-scores: the competitiveness scores range from 6.39 (Slovenia) to 1.85 (Croatia). Slovenia and Hungary reach levels comparable to “average” EU-15 countries, whereas Estonia and Croatia lag behind. In between, Latvia, Bulgaria, and the Czech Republic score highest, mainly thank to good scores in unbundling. On the other hand, Lithuania, Poland, Romania and Slovakia obtain mediocre scores for network access, TPA, and price transparency.

Even though the three benchmarking exercises (EU, EBRD, DIW/EE<sup>2</sup>) are not directly comparable, there is a high degree of convergence between the results. Some discrepancy between the scores can be explained by differences in weights. Thus, the discrepancy between the scores of DIW/EE<sup>2</sup> and EBRD for Slovenia can be explained by the high scores of the country in the network unbundling in the DIW/EE<sup>2</sup>-score. The OXERA-methodology attaches particular weight to this criteria. Estonia is

another example where we find slight differences: whereas it scores low in the EU-Benchmarking and the DIW-EE<sup>2</sup> ranking, EBRD had placed Estonia on top of its list in 2000 and 2001 (4.0). However, EBRD downgraded Estonia in 2003 and 2004, thus confirming the rather critical assessment of the other two scores. Overall, it is fair to conclude that the DIW/EE<sup>2</sup>-score confirms the estimates and the ranking by the European Commission and EBRD, but it also points to the need of a more in-depth analysis and quantification.

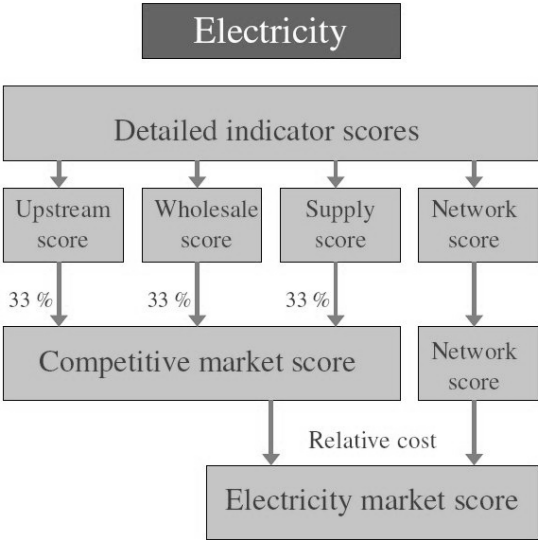

Source: Oxera (2003, 4)

**Figure 2: Summary of OXERA Competitiveness Scoring System**

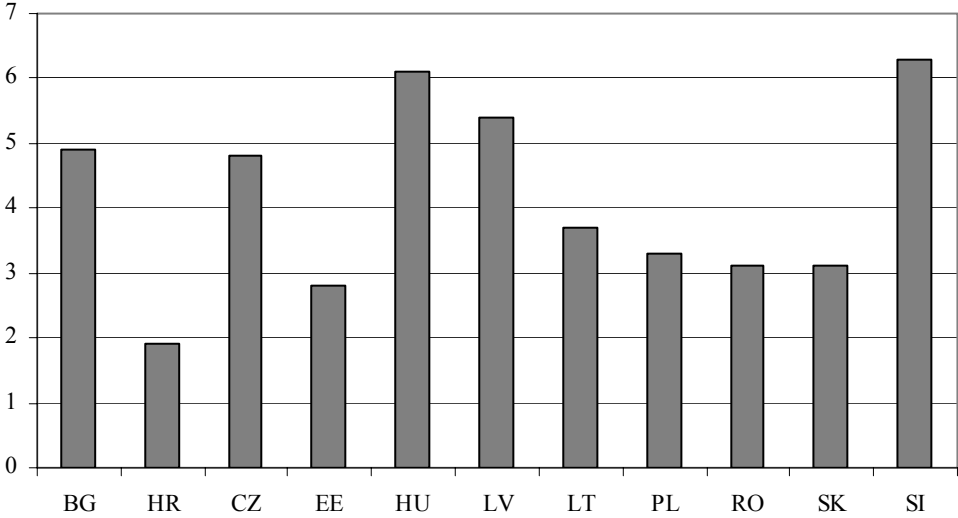

Source:

Apfelbeck, et al. (2005, 64)

**Figure 3: Competitiveness Score for East European Electricity Sector**

### **3.4 Remaining Obstacles to Competitive Markets**

The three different benchmarking exercises, though differing in detail, suggest that regulatory reforms in Eastern Europe still leave a lot to be desired. After considerable progress in the late 1990s, it now seems as if the creation of competitive markets has slowed down recently. Foreign investment, though important for raising funds and improving internal efficiency, can only partially be expected to enhance domestic competition, and may perhaps impede international competition by creating a Europe-wide oligopoly. Unbundling at the distribution level has only been done in accounting terms in most new member countries. But even at the level of transmission system operation, unbundling was half-hearted in many cases, and third party access (TPA) to the transmission grid is not regulated efficiently. Thus, e.g. Hungary's MVM, the owner of the transmission grid, remains de facto vertically integrated, with major stakes in electricity generation, and some engagement in distribution. Likewise, Croatia hangs on to vertical integration, centred around a market-dominating electricity producer.

Concentration in electricity generation (as measured for example by the Hirschman-Herfindahl-Index) remains high in most new member countries. Since most of these systems are small, high domestic concentration is rather natural, and could be offset by international trade. This, however, is not the case, so that often the relevant market is still national, not regional. Recent trends to reintegration might limit the extent of competition (such as the proposed merger between the dominant players in the Czech Republic and in Slovakia). Poland is also taking action to concentrate generation capacities into few large production associations. The idea that "national champions" are required to withstand foreign investors and competitors is gaining popularity in the region, which thus emulates similar earlier trends in the EU-15 electricity markets.

There are practically no workable wholesale markets operating in the region. Table 4 summarizes the current state of wholesale markets in Eastern Europe, and their respective market share. The largest wholesale market, the Polish Power Exchange (PolPX) trades only 1% of total electricity consumption, and suffers from low liquidity. The day ahead trade organized by the Czech market operator OTE and the spot market of the Slovenian power exchange Borzen are characterized by volumes that regularly fail to provide price signals for certain hours. Since no liquid electricity market exists in the region, behavior of wholesale prices remains intransparent. In a companion paper to this report, Zachmann (2005) explores price differentials between wholesale markets, and confirms that the East European wholesale markets are not functioning properly.

The underdevelopment of wholesale markets in the region can also be explained by the legacy of long-term power purchase agreements (PPA), which, for the largest part, have not been struck according to market terms (e.g. in Poland, Hungary, the Czech Republic). Thus, competition authorities need to distinguish between PPAs, signed between producers and consumers, which are an important institution to ensure investment adequacy and reduce market power, and "old" post-socialist PPAs which enable incumbent large producers to sell the output of small producers and therefore enhance their effective market share and power. One way of resolving the issue is to make these PPAs tradable in the market and to restrict dominant players from access to PPAs that enhance their market power.

	Marketplace	Traded volume in the day ahead market 2004	Traded volume as % of total electricity production in 2004
Poland	PolPX	1.9TWh	1.4%
Slovenia	Borzen	0.3 TWh	0.5%
Czech Republic	OTE	0.3 TWh	2.2%

Source: power exchanges websites

**Table 4: Wholesale electricity markets in Eastern Europe**

## 4. Generation Adequacy, Fuel Mix, and Sustainability

### 4.1 Generation Adequacy

We now turn to the production side, and analyze issues related to the modification regarding fuel mix, sustainability, and investment. Concerns about a backlog of investment in generation capacity in the new member countries are wide-spread. Thus, Haas, et al. (2005) express worries that insufficient investment into new generation facilities might be forthcoming to meet the expected increase in demand. However, a closer look at the forecasts suggests that the concerns seem to be unfounded, at least to large extent. This assessment is shared by the UCTE (2005b, 7) which forecasts a shortfall of reliable generation capacity until 2015 in Europe, but not for the East European countries. At present, overcapacities in the region are still substantial, and the life-time of most of the power plants can be extended by another 10-15 years. Electricity consumption is only increasing gradually; in addition, this growth will be contained if the necessary price increases will be implemented. Also, semi-commercialization and only half-hearted price adaptation reduce the commercial interest to invest in new generation capacities in new member states. In some cases, a lack of political commitment to reforms and/or time inconsistency of the regulators add to political and economic risk of investment.

### 4.2 A “Politically Incorrect” Fuel Mix: Coal and Nuclear

With the Green Paper “Towards a European Strategy for Security of Energy Supply”, the European Commission expressed its beliefs about how the energy import dependency of the EU can be managed.<sup>14</sup> Major roles have been attributed in this context to the extension of renewable energy sources, energy saving and development towards a fuel mix consisting of different energy types from a variety of regions. However, in Eastern Europe, the fuel mix is, similar to the grid structure, still heavily influenced by historical developments. On the one hand, countries with own natural energy resources concentrated their power production on those domestic fuels, on the other hand import dependent countries focused on Soviet oil, gas and uranium. Apart from hydro power stations, renewable energy utilization was virtually absent in the socialist countries. As a consequence, we today observe a large discrepancy between the political vision to move towards a renewable and non-carbon fuel mix, and current reality. The latter is that traditional energy sources, considered to be dirty or dangerous, are thriving: *coal* and *nuclear* energy. Figure 4 shows the composition of net electricity

<sup>14</sup> The European Commission estimates that by 2020, 70% of the EU's primary energy needs will be met by imports.

production in Eastern Europe in the year 2003, and Table 5 shows the percentages of different primary energy sources. Whereas traditional conventional thermal plants and nuclear power plants dominate, hydropower also plays a certain role. Other renewable energy sources have not yet reached sufficient maturity to play a significant role in the fuel mix; their share is negligible.

*Coal* (mainly lignite, some hard coal) is experiencing continuous popularity in several countries. Coal is the only primary energy source in significant amounts in the region, and there is a strong propensity to continue to rely on this domestic fuel. This is particularly striking in *Poland*, where over 90% of electricity production is based on hard coal and lignite. Poland's annual production of around 100 mn t hard coal and around 60 mn t lignite places it on top of European coal producing countries. This also entails important socio-economic consequences (employment, regional economic development, etc.). The *Czech Republic* (20 mn t hard coal, 50 mn t lignite), *Romania* (3 mn t hard coal, 27 mn t lignite), *Bulgaria* (23 mn t lignite) and *Hungary* (13 mn t lignite) are large coal producers, too.<sup>15</sup> It is unlikely, that the East European governments will push to reduce coal utilization. Also, at current CO<sub>2</sub>-prices, the European emissions trading scheme is unlikely to modify the balance, though in the mid-term, coal production might be penalized by CO<sub>2</sub>-prices and thus be reduced.

*Nuclear power* is another energy source that most new East European EU member states hang on to vividly, and even try to expand in some cases. Although the recent history of nuclear power plants in Eastern Europe is full of technical incidents, and the economics of newbuilds is all but proven, nuclear energy is considered as a strategic source to relieve the energy problems of the future. Table 6 gives an overview of nuclear power stations in the region. In Lithuania (64%), Slovakia (55%), Bulgaria (40%), Hungary (39%) and the Czech Republic (33%) nuclear power will account for more than one third of the power generated in 2005 (Eurelectric, 2004). Several countries have announced plans to expand nuclear energy, e.g. Romania (Cernavoda 2, to be commissioned in 2006), Slovakia (Mochovce 3 and 4), and Bulgaria (reactivation of the project in Belene). There are high sunk costs into expansion or new builds, and how these projects will be financed is rather unclear at present.

It is sometimes argued that Eastern Europe might increase its exports of nuclear electricity to Western Europe significantly. A rough economic calculation suggests that this is an unlikely scenario, as transportation costs make nuclear electricity from the East uncompetitive in West European markets. Hirschhausen and Rüster (2004) provide a back-of-the-envelope calculation of the cost for nuclear energy from newbuilds in Western Europe (European Pressurized Reactor, ERP) vs. East European Plants. Assuming cost advantages (fixed and variable) for East European plants, the average revenue requirements are in the range of 4.5 € Cent/kWh in Western Europe, and 3.5 € Cent/kWh in the East. However, if one adds *transportation costs* of approx 0.25 € Cent/kWh/100km, and an average transport distance of 1,000 km, East European nuclear electricity has a clear cost disadvantage (at about 6 € Cent/kWh).<sup>16</sup>

	BG	CZ	EE <sup>17</sup>	HU <sup>18</sup>	LV	LT	PL	RO	SI	SK
<b>Nuclear</b>	39%	33%	0%	39%	0%	63%	0%	9%	38%	55%

<sup>15</sup> Statistik der Kohlenwirtschaft e.V. (2003).

<sup>16</sup> Two further peculiarities on the fuel mix in the CEECs should be highlighted. First, the importance of gas for power generation is less developed in East Europe. Only in Latvia and Hungary it accounts for more than 30% of the generation. Second, combined heat and power is more important than in the West.

<sup>17</sup> Data for Estonia are the real values for 2002, the coal value (originally 0) was replaced by the oil shale value.

<sup>18</sup> Conventional thermal shares as of 2002 (Eurostat, 2004).

<b>Conventional thermal</b>	54%	64%	98%	61%	40%	28%	97%	61%	35%	29%
Coal	11%	10%	82%		0%	0%	53%	9%	34%	9%
Brown coal	36%	49%	0%	25%	0%	9%	40%	29%	0%	7%
Oil	3%	0%	1%	6%	6%	19%	0%	17%	1%	1%
Natural gas	4%	2%	16%	30%	33%	0%	4%	5%	1%	12%
Derived gas	0%	2%	0%	0%	0%	0%	0%	0%	0%	0%
<b>Conventional hydro</b>	6%	2%	0%	0%	58%	4%	2%	30%	27%	15%
<b>Hydro pumped</b>	1%	1%	0%	0%	0%	4%	1%	0%	0%	1%
<b>Other renewables</b>	0%	1%	2%	0%	2%	1%	0%	0%	0%	1%

Source: Eurelectric (2004)

**Table 5: Primary energy share of electricity production in 2005 (predicted)**

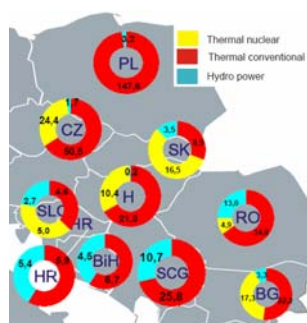

Source: UCTE database as of 31.12.2004

**Figure 4: Net electricity production in CEECs in 2003 (TWh)**

Country	Location	Type of Reactor	Capacity (MW/net)	Legal Status	Technical Status
CZ	Temelin	PWR <sup>19</sup> , WWER 1000	1 x 981		
		PWR, WWER 1000	1 x 981		
	Dukovany	PWR, WWER 440/213	4 x 417		modernization program
SK	Bohunice	PWR, WWER 440/230	2 x 408	closure in 2006	improvements in safety, 1996 started program of incremental reconstruction => life time increase
		PWR, WWER 440/213	2 x 408	closure in 2008	
	Mochovce	PWR, WWER 440/213	2 x 408		
		PWR, WWER 440/213	2 x 408	under construction	
H	Paks	PWR, WWER 440/213	4 x 430	closure > 2020	recent problems of block 2 resolved
SLO	Krsko <sup>20</sup>	Westinghouse PWR	1 x 632	closure in 2023	modernization took place
RO	Cernavoda	Canadian Deuterium-Uranium-Reactor	1 x 630	under construction	safety improvements
		CANDU 600	1 x 630	1 block completion 2006	
			3 x 630	2 blocks completion 2010	
LT	Ignalina	RBMK 1500, water cooling, graphite moderator	2 x 1185	1 block closure in 2004, 1 block closure in 2009	adjustment: 1300MW gross, improvements
BG	Kosloduy	PWR, WWER 440/230	2 x 408	closed in 2003	improvements in control technology/cooling/ radiation- & fire protection
		PWR, WWER 440/230	2 x 408	closure in 2006	
	Belene	PWR, WWER 1000	2 x 953	modernization	
		PWR, WWER 1000	2 x 953	construction stop in 1990	completion unrealistic

Sources: Jahrbuch der Atomwirtschaft (2001), EIA, IAEA

**Table 6: Description of East European nuclear power plants**

### 4.3 Insufficient Incentives for the Promotion of Renewable Energy

The attempts to promote the role of *renewable* energies in the fuel mix have been unsuccessful thus far. It seems that environmental concerns have often been outweighed by economic interests. The overall share of non-hydro renewable in electricity generation is negligible (between 0% and 2%, see above Table 5). *Hydroelectricity* is the only “renewable” energy source with a significant market share in some East European countries. In Latvia hydropower is the clearly dominating source of electric energy with 60-70% of the net production (natural gas making up for the remaining 30-40%). In

<sup>19</sup> PWR = Pressurized Water Reactor

<sup>20</sup> 50% property of Croatia.

Croatia, hydropower makes up for around 47% of electricity produced. Finally, Slovenia (>40%) and Romania (>25%) are also characterized by high shares of hydropower. Given that the existing potential of hydropower has been tapped, an expansion of this energy source in the fuel mix is unlikely.

Development of *wind power* has to be considered a failure so far, its market share in the region remaining about 0.2% (in 2002). The new member states are still far away from the target fixed in the directive 2001/77/EC on electricity from renewable energy sources (11% of electricity generation in 2010). The Czech Republic provides the highest feed in tariffs in the region (9.6 € Cent/kWh), but the wind resources of the country are quite limited. Poland has the largest wind resources in the region, but the country has yet to come up with a consistent renewable policy. Likewise, *solar energy* (photovoltaic) and *biomass* play an insignificant role in the fuel mix thus far. Clearly, political support for renewable energies in the new member countries has been lukewarm so far. Table 7 summarizes the policies of the East European countries in the field of renewables. Even though some countries provide significant feed-in tariffs (e.g. the Czech Republic and Latvia), these have not had the same effects as, say, in the German wind promotion. Insiders explain this with legal uncertainty and the unstable regulatory environment that investors are facing. It would require a particular political effort to increase the role of renewable energies. This might involve long-term contracts for energy take off or legally binding feed in tariffs. What is also needed is the combination of international technology and local learning. Governments should push for the initial percentages of market share, in order to allow the renewables to start reaping scale economies.

	<b>CZ</b>	<b>PL</b>	<b>SK</b>	<b>SLO</b>	<b>HU</b>	<b>LV</b>	<b>EE</b>	<b>LT</b>
Wind	9,6	none	none	6,2	6,4	7,5	5,2	case by case
Hydro	5,0	none	none	6,0	6,4	6,9	5,2	annually fixed
Biomass/gas	8,0	none	none	6,8	6,4	6,9	5,2	annually fixed
PV	19,2	none	none	6,1	6,4	n.a.	5,2	annually fixed

Source: European Commission (2004)

**Table 7: Feed in tariffs in new member states**

## 5. Network Interconnection and Regional Markets

### 5.1 Three Regional Markets

This section studies a core issue of European electricity integration, i.e. network interconnection in Eastern Europe, and with the former EU-15. Even though the East European countries have joined the European single electricity market, they are still far from being fully integrated with their Western neighbors, let alone with the EU-15 as a whole. At present, cross-border trade plays but a minor role (below 10% of total electricity consumed). Table 8 summarizes the flows between the East European countries as well as with their major Western neighbors.

Basically, there are two strategies with respect to market design and regional integration: i) the *individual* approach consists of each country developing its own market arrangement while respecting a minimum set of common rules on cross-border trade. In this model, close market integration is only gradually pursued later on; ii) a *regional* approach would consist of putting in place a standard market design model for the organization of the electricity markets of the region. The regional approach is

preferable if one wants to progress towards a single European market. However, reality shows that national strategies may be difficult to coordinate. For instance, the three Baltic countries have been unable to coordinate their electricity markets thus far, though each of them is small and very simply structured. Eastern European countries seem to be “muddling through” rather than to develop a coherent strategy of integration.

With regard to the network, the region can be divided into three regional markets:

- The Central East European Countries (CECs, see Section 2) are the core zone and the only one with significant electricity exchange with its Western neighbors. However, the interconnections to the western neighbors are insufficient.
- even though South Eastern Europe (SEE) joined the first tier UCTE system in 2004, electricity trade remains underdeveloped;
- the Baltic countries (Lithuania, Latvia, Estonia) are still part of the North-West Russian electricity system, and nothing indicates that they would join UCTE in the near future. Within the three Baltic countries, the electricity network is technically well developed with strong interconnections between the three countries and their eastern neighbors. But up to now Lithuania, Latvia and Estonia do not have any transmission lines to UCTE or NORDEL countries. Although there is a transmission line under construction from Estonia to Finland and plans exist for an interconnection with Poland it remains unclear whether the project of a Baltic ring (transmission system of Poland, the Scandinavian and the Baltic countries) will materialize in the medium-term future.

Country	D	I	SLO	HR	A	CZ	H	PL	SK	RO	BG	S
D					7682	144		3158				1446
I			3		0							
SLO		6180		1785	186							
HR			5437				0					
NL	558											
A	4158	1481	1886			9	462					
CZ	13116				5544			80	6045			
H				4558	660				0	14		
PL	450					9150			2624			2375
SK						463	7737	8				
RO							124				732	
BG										989		
S	1270							213				

Source: UCTE database as of February 2005

**Table 8: Physical electricity exchange in GWh (2004)**

## 5.2 Congested Transmission Lines

Relatively small cross-border capacities and insufficient allocation of these capacities lead to regular congestion on most connections in the region. In addition, congestion between Eastern Europe and its Western neighbors enforced by the cost structure of electricity generation: Poland, the Czech Republic and Slovakia have inexpensive surplus capacities for which Germany, Hungary and Austria are potential markets. Because of business or political (nuclear power) reasons, these countries are successfully opposing the commissioning of new transmission lines that could resolve the above

described bottlenecks. Thus the profitable exporting lines (CZ->D, PL->D, SK->HU, CZ->A) are almost always congested.

Figure 6 shows the physical energy flows in the region, whereas Figure 5 indicates the occurrence of congestion (the four arrows at each border signify the import/export congestion occurrence as seen by the importing/exporting country). In its “System Adequacy Forecast”, UCTE (2005) provides an assessment on the future development of the European interconnection and generation capacities, as well as the potential bottlenecks.

Table 10 lists the existing transmission lines between the old and the new EU member states, whereas Table 9 reveals the most important planned network extensions in the region. This planning also indicates which bottlenecks will persist, and which ones might be removed. For example the German-Polish cross-border bottleneck will be resolved at earliest in 2010, and the German-Czech transmission, deficiency will not be removed before 2015 by way of increasing the cross-border capacity.

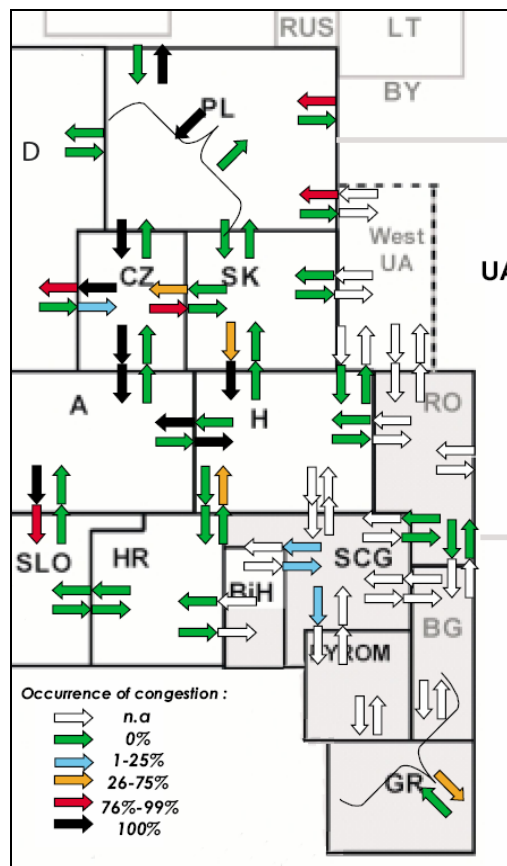

source UCTE (2004b)

**Figure 5: Occurrence of congestion in Central/South-East European countries in 2003**

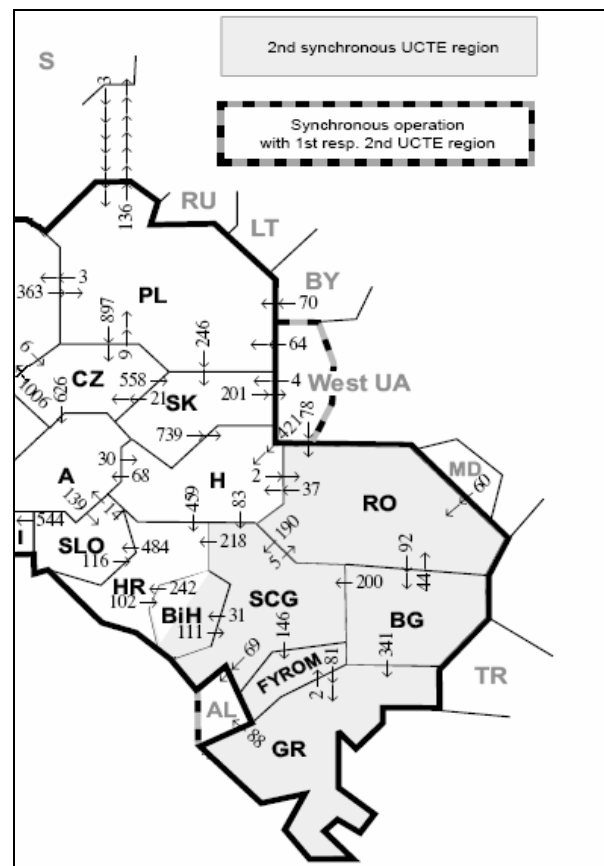

source: UCTE (2005a)

**Figure 6: Physical energy flows in October 2004 (GWh)**

Line or equipment	Voltage level	Date of commissioning	Cross-border
PST Hagenwerder - Mikulowa		>2010	D - PL
2nd line Slavetice - Durnrohr	400 kV	2006	CZ - A
Lienz – Cordignano Line	400 kV	2008	A -I
Double AC tie-line Robbia – San Fiorano	400 kV	2005	CH -I
Okroglo - Udine	2 x 400 kV	2011	SLO - I
Cirkovce – Pince Line	400 kV	2010	SLO - H
OHL Nadab –Bekescsaba	400 kV	2007	RO -H

Source: UCTE (2005b)

**Table 9: Selected list of main developments on interconnections in Central and East European countries 2005 to 2015**

Country	Transfer capability	EU15 country	
Poland	1*400 kV	530 MW	Germany
	2*400 (220) kV	310 MW	
	2*220 kV	310 MW	
	1*110 kV	35 MW	
	1*450 kV DC	600 MW	Sweden
Hungary	1*400 kV	530 MW	Austria
	2*220 kV	310 MW	
Czech Republic	1*400 kV	515 MW	Austria
	2*220 kV	310 MW	
	2*2*400 kV	2060 MW	
	2*220 kV	310 MW	Germany
Slovenia	2*400 kV	1030 MW	Austria
	1*220 kV	155 MW	
	1*400 kV	515 MW	
	1*220 kV	155 MW	Italy

Source UCTE (2005b)

**Table 10: Transmission lines between old and new member states (2004)**

### 5.3 More Efficient Allocation Mechanisms Required

Congested transmission lines, and eventually the construction of new transmission lines, could be avoided at least partially by using more efficient mechanisms of allocating the available capacities. Inefficient capacity pricing hampers the emergence of regional markets. Capacity auctions for interconnections are underdeveloped and often intransparent.

The ETSO report on “Current Cross-border Congestion Management Methods in Europe” evaluates existing transmission capacity allocation schemes between ETSO members and then describes the mechanism at each border in detail (see Figure 7). Although explicit auctions have been implemented formally, in practice they do not play a significant role yet. Thus in the triangle between Poland, the

Czech Republic and Germany, internet-based day-ahead auctions have so far been regularly postponed.

The increased use of formal auctions to allocate transmission capacity, might be a first step towards good practice; in particular, it would be superior to “grandfathering”. However, auctions themselves are inferior to integrated congestion pricing. Neuhoff (2004) has shown that integration of regional markets is more efficient than auctioning cross-border capacities. An additional, more far reaching criticism of the existing system of allocation is that *uniform* network access prices within the countries do not take into account congestion, leading to a suboptimal use of transmission capacity. Some form of *locational network pricing* should be introduced to make more efficient use of the existing transmission capacity, both at the national and at the cross-border level (see Green, 2004, for a concrete analysis of the UK grid). Only then can reasonable decisions on the construction of *new* transmission lines be taken. One also needs to consider that the costs of implementing these reforms are high, and need to be justified by expected welfare gains. In any case, a very strong, mutual political will be required to push through additional interconnection projects.

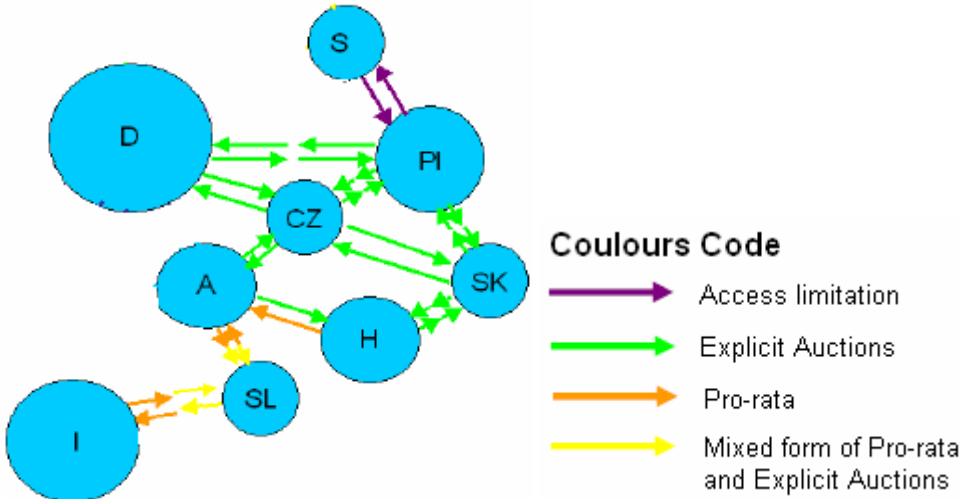

Source: ETSO (2004)

Figure 7: Congestion Management Methods in CEE

6. Conclusions

In this paper, we have reviewed the process of European electricity enlargement towards Eastern Europe, and towards a single sustainable electricity market. Whereas the political EU-enlargement can already be considered as a success, the electricity enlargement is far from being achieved. The experience from the last decade shows that electricity enlargement is not a linear “transition” of the new member states towards a pre-defined ideal type model of the EU-electricity sector. Rather, the reform path resembles a stormy journey, where two steps in the right direction may be followed by one step back, or one step sideward. Hence the remaining policy issues are broad, ranging from the establishment of the appropriate regulatory framework, the creation of efficient wholesale markets, to instruments to foster a sustainable fuel mix and sufficient generation capacity. A more pro-active energy policy is required by the new member states themselves, but also by the European Union in

order to achieve these goals. It is not clear at this point what the right level of decision is, but it seems that there is a necessity to find European-wide solutions, and that reforms need to be structured top-down, rather than bottom-up, in this particular case.

The development of competitive markets in Eastern Europe is closely related to the region's ability to enhance cross-border flows. This requires a more efficient use of the existing capacities, a change of the regulatory regime of cross-border trade, a more efficient pricing system for congested transmission lines and – eventually – the construction of new domestic and cross-border transmission capacities. International trading relies on, but can at the same time enhance, the liquidity of local energy markets.

In the medium term, it will become more important to look beyond the current EU and UCTE borders. In particular, *Russia* and *Ukraine* are emerging as the new “frontier” of the EU electricity market. Physical interconnection with the former CENTREL-countries could be reactivated, e.g. a 750 kV line between Hungary and Ukraine. Large exports of (nuclear) electricity from Russia and Ukraine towards the EU seem unlikely in the future, but at the regional level these two countries will play an increasingly important role for trading, perhaps also for investment. Not least because of the targeted expansion plans of the new Russian national energy champion, Gazprom.

## 7. References

- Apfelbeck, Jürgen, und René Pessier (2005): Bewertung des Osteuropäischen Elektrizitätsmarktes- Was sind die eingeleiteten Reformen wert? Dresden, TUD-EE<sup>2</sup> Working Paper „Eastern Europe“, WP-EE-10.
- Bradke, Harald, Clemens Cremer and Wilhelm Mannsbart (2001): Potenziale für den Import und Export von Strom. Karlsruhe, ISI.
- European Commission (2003): European Energy and Transport - Trends to 2030. Luxembourg, European Commission DG TREN.
- European Commission (2004): The share of renewable energy in the EU Country Profiles Overview of Renewable Energy Sources in the Enlarged European Union. Brussels, Commission Staff Working Document COM(2004)366 final.
- European Commission (2005): Fourth Benchmarking Report on the Implementation of the Internal Electricity and Gas Market. Brussels, DG TREN Draft Working Paper, (January 5).
- EBRD (1996): Transition Report – Infrastructure and Savings. London, European Bank for Reconstruction and Development.
- EBRD (2004): Transition Report 2005. London, European Bank for Reconstruction and Development.
- EEG (2004): GreenX – „Deriving Optimal Promotion Strategies for Increasing Share of RES-E in a Dynamic European Electricity Market“. Vienna University of Technology.
- Encharter (2003): Regional Electricity Markets in the ECT Area. Brussels, Encharter.
- ENTSO (2004): An Overview of Current Cross-Border Congestion Management Methods in Europe. Brussels, European Transmission System Operators.

- Eurelectric (2004): Statistics and Prospects for the European Electricity Sector (1980-1990, 2000-2020). Brussels, Union of the Electricity Industry.
- Global Competition Review (2004): Electricity Regulation 2004. London.
- Green, Richard (2004): Electricity Transmission Pricing: How Much Does it Cost to Get it Wrong? mimeo, University of Hull Business School.
- Haas, Reinhard, Nenad Keseric, Gustav Resch, Claus Huber and Hans Auer (2005): Medium- and Long-Term Effects of EU-Electricity Enlargement. Vienna, Background paper for SESSA Work Package 5 “Ensuring Sustainable Electricity Enlargement.
- Hirschhausen, Christian von (2002): Modernizing Infrastructure in Transformation Economies – Paving the Way to European Enlargement. Edward Elgar, Cheltenham, UK and Northampton, MA, USA (2002).
- International Energy Agency (various years): Country Reports. Paris, OECD.
- Jahrbuch der Atomwirtschaft 2001. Bonn, INFORUM Verlag u. Verw. Ges..
- Kaderják, Péter (2005): A Comparison of Electricity Market Models of CEE New Member States. Budapest, Background paper for SESSA Work Package 5 “Ensuring Sustainable Electricity Enlargement”.
- Kennedy, David, 2003: Power Sector Regulatory Reform in Transition Economies: Progress and Lessons Learned. Working paper No. 78, Vol., No.
- Kreibig, Uta, Petra Opitz, and Christian von Hirschhausen (2001): The Power Sector in Central and Eastern Europe: More Competition Needed in the Run-Up to EU Membership. Economic Bulletin, Vol. 38, No. 1 (January), 33-38.
- Neuhoff, Karsten (2003): Integrating Transmission and Energy Markets Mitigates Market Power. Cambridge, CMI Working Paper 17.
- Newbery, David (1994): Restructuring and Privatizing Electric Utilities in Eastern Europe. Economics of Transition, Vol. 2, No. 3, 291-316.
- Newbery, David (2002): Problems of Liberalizing the Electricity Industry. European Economic Review, Vol. 46, No. 3, 918-927.
- Opitz, Petra, and Christian von Hirschhausen (2001): Power Utility Re-Regulation in East European and CIS Transformation Countries: An Institutional Interpretation. Paper prepared for the Annual Conference of the International Society for New Institutional Economics (ISNIE), September 13-15, 2001, Berkeley (USA). also as DIW Discussion Paper 246.
- OXERA (2003): Energy Market Competition in the EU and G7: The Relative Extent of Energy Market Competition in the EU and G7. London, Oxford, Report on Behalf of the UK Department of Trade and Industry.
- Ragwitz, Mario (2004): FORRES 2020: Analysis of RES’s evolution up to 2020. Presented at the Conference on “Renewables”, Bonn (June).

- Stern, Jon (2003): The 2002 European Union Electricity Directive and its Implications for the Countries of Central and Eastern Europe. London Business School; Regulation Initiative Public Policy Paper Series (2003-1).
- Stern, Jon (2004): The Reform Agenda Ahead. Berlin, Presentation given at the SESSA Berlin Conference “Perspectives and Challenges of EU Electricity Enlargement”, 9 December.
- Stern, Jon, and Junior R. Davis (1998): Regulatory Reform in the Electricity Sector in Eastern Europe. *Economics of Transition*, Vol. 6, No. 2, 427-460.
- UCTE (2004a): Half-yearly Report I/2004. Brussels, Union for the Co-ordination of Transmission of Electricity.
- UCTE (2004b): UCTE System Adequacy Retrospect 2003. Brussels, Union for the Co-ordination of Transmission of Electricity.
- UCTE (2005a): Monthly Statistics 10/2004. Brussels, Union for the Co-ordination of Transmission of Electricity.
- UCTE (2005b): UCTE System Adequacy Forecast 2005 – 2015. Brussels, Union for the Co-ordination of Transmission of Electricity.
- Zachmann, Georg (2005): Convergence of Wholesale Electricity Prices in Europe? - A Time Series Analysis of Hourly Spot Prices. Berlin, Background paper for SESSA Work Package 5 “Ensuring Sustainable Electricity Enlargement”.